

File IFR In The Thick Of It

Imagine your instrument flight traveling through a column of air. Determine how thick the column is to get a clearer look at IMC.

When you flip to the evening news and watch the local weather personality, you'd expect to hear terms like temperature, dew point, relative humidity, wind chill, and maybe pressure. Have you ever heard them talk about thickness?

Say again...thickness? No, I'm not referring to woodworking; I am talking about meteorology. Unless you've worked as a meteorologist or are truly a weather nerd, you probably haven't heard this term ever used relative to the weather. Don't go running for your dictionary. It won't have a weather-related definition of thickness either.

While not specific to weather, the dictionary definition is not too far off base, however. Atmospheric thickness is simply a measurement of the difference in height of two constant

pressure surfaces. Even though any two constant pressure surfaces can be used, the two most common used by meteorologists are the 1000 mb and 500 mb surfaces. This parameter is referred to as the 1000-500 mb thick-

“ If you can subtract two numbers you can calculate the thickness parameter. ”

ness. The 500 mb surface is at approximately 18,000 feet and the 1000 mb surface is roughly sea level.

Constant Pressure Surfaces

What is a constant pressure surface? Class A airspace drivers that hit the

flight levels on a routine basis are intimately familiar with a constant pressure surface. In class A airspace (the airspace that's 18,000 feet and above and is also at least 1200 feet above ground level) you're required by regulation to set your altimeter to 29.92 and keep it there until you descend below FL180 at a later time. As you fly toward an area of lower pressure in this airspace you lose geopotential height.

Geo-what?

Losing geopotential height is just a meteorological way of saying you are losing true altitude or getting closer to the ground.

Conversely, if you fly toward an area of higher pressure without adjusting your altimeter, you'll gain geopotential height; that is, you'll move farther from the surface of the earth.

In both cases you're flying a constant pressure surface. Similarly, upper air charts such as the 500 mb chart are constant pressure charts. They depict the geopotential height of the 500 mb surface. The key word here is height.

I hope you see where I'm going with this. If you can subtract two numbers, you can calculate the thickness parameter.

For example, if you know the height of the 500 mb surface and the height of the 1000 mb surface, you can calculate the difference in height of these two surfaces. In effect, you've found the thickness of the atmosphere between 500 mb and 1000 mb. Impressed?

It's time for a couple of examples. Pick your favorite vacation spot and let's calculate the thickness above this location. Let's say the height of the 500 mb surface is 5407 meters and the height of the 1000 mb surface is 23 meters.

Okay, what is the 1000-500 mb

How To Determine WAA And CAA

Determining areas of warm-air advection (WAA) or cold-air advection (CAA) is fairly easy, even to the untrained eye.

What you're looking for are regions where the wind is blowing perpendicular (90-degree angle) to

the isotherms or lines of constant temperature. Advection is strongest in areas of the highest temperature gradient, strongest winds and the most perpendicular flow.

While not isotherms, wind that's blowing perpendicular to the lines of constant thickness is also indicative of thermal advection as can be seen in the diagram.

On the other hand, a wind that's blowing parallel to the thickness lines or isotherms represents the lack of thermal advection.

Similarly, light winds and a small temperature gradient contribute less to thermal advection.

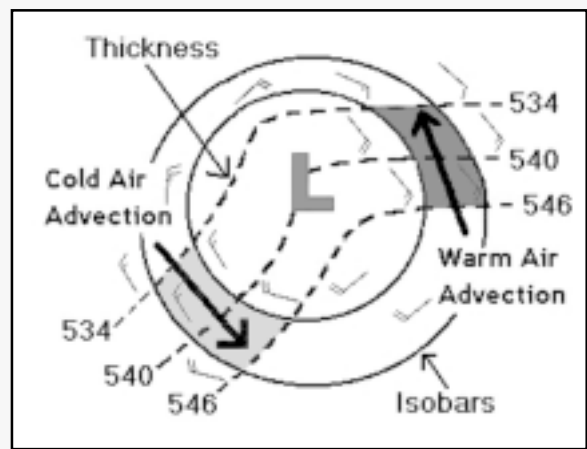

thickness at this location? Using the most basic mathematics possible, simply subtract the height of the two surfaces: $5407\text{ m} - 23\text{ m} = 5384\text{ m}$ or 538 decameters.

Ah, but you say that your favorite vacation spot is in the mountains? It is very possible that the 1000 mb surface may actually be below elevation. From a pilot's perspective, this is not usually an issue. You just have to remember that the 1000-500 mb thickness value is a calculation between two pressure surfaces even though it is very likely one of the pressure surfaces may be below the surface. This is exactly what is done with the familiar mean sea level pressure.

It gets better, so bear with me. Now that you have calculated the thickness of the atmosphere, what do you do with this little nugget of information?

Strangely enough, the thickness of the atmosphere directly relates to the average virtual temperature in this arbitrary column of air. Therefore, a thicker atmosphere has a higher average temperature (virtual temperature also includes the presence of moisture). Conversely, a thinner atmosphere has a lower average temperature.

This temperature-thickness relationship is most notable at the equator and at the poles. The tropopause—the top of the troposphere—rises to approximately 17 km at the equator and falls off to approximately eight km in the Polar Regions. On the planetary scale, this difference in thickness is directly related to the average atmospheric temperature in these regions. Still not convinced?

Proof Is In The Molecules

Another way to picture this is to imagine a block of air touching the surface of the earth and extending upward to 18,000 feet. What happens to the air molecules when you heat this block of air?

They move faster due to the higher energy from the increase in temperature and the molecules are forced farther apart from each other.



In other words, the density in this block of air must decrease. We have not removed or added molecules to this block of air; therefore, the air pressure we feel at the surface remains exactly the same. The result is that the block of lower-density air expands upward and the top of this block of air must therefore *grow* in height.

The same holds true when we slow down the molecules by cooling this same block of air. As the molecules lose energy, they move slower and are allowed to compact together. Therefore, the density of the block of air increases. Because we have not removed or added molecules, this theoretical block of air must therefore *shrink* in height.

As you can see, measuring or forecasting the atmospheric thickness can tell us a lot about the average temperature of the atmosphere.

Take note that thickness represents an *average* temperature; it's measured in meters and not in degrees and therefore is not a direct way to predict the surface temperature or the temperature at any intermediate altitude.

I'll use an example to illustrate this important point. Let's assume a block of air that decreases in temperature using the standard lapse rate of two degrees C per 1000 feet on a standard

Above: Many ways to analyze the atmosphere. Determining its thickness is just one step in the process.

day (15 degrees C at the surface). We measure the difference in height between the 1000 mb surface and the 500 mb surface to be 5600 meters, for example.

Next, we increase the air temperature in this block of air near the surface. At the same time, let's make an equivalent decrease in temperature near the top of the block of air. Again, we measure the height difference to be 5600 meters. Effectively, the standard block of air and the modified block of air have the same thickness, but have a very different temperature profile.

Thermal Advection

Okay, enough molecular theory. How do you make use of this strange parameter called thickness? One common use by meteorologists is to identify areas of thermal advection, or more specifically, warm- and cold-air advection.

Warm-air advection (WAA) is simply defined as the transport of warm air in the horizontal driven by the movement of warm air into a colder

MSL Pressure Surface Chart

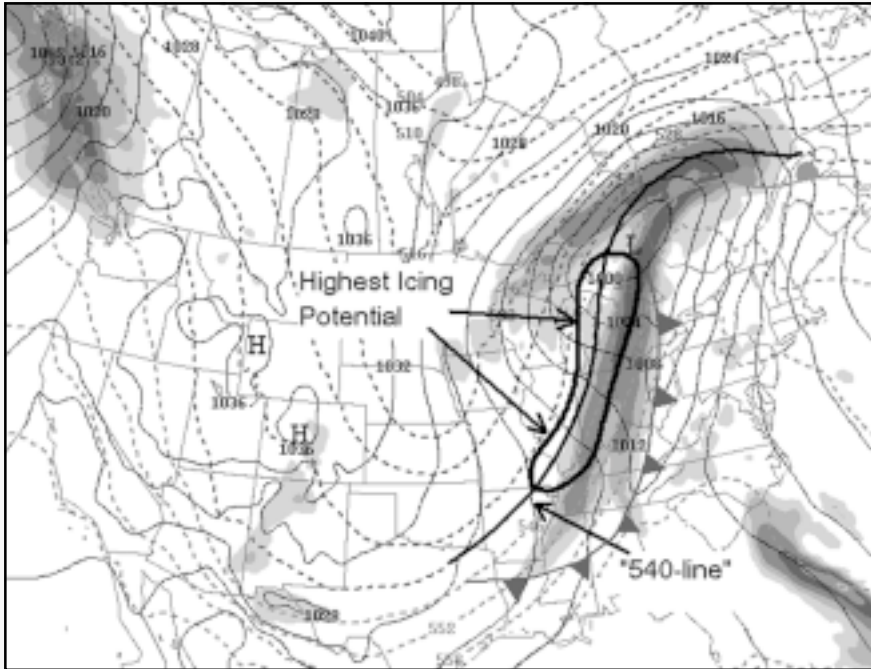

The best place to visualize thermal advection is on the MSL pressure surface chart. 1000-500 mb thickness is depicted as an overlay of dashed lines on this Eta surface forecast (Eta represents the Greek letter and really isn't terribly important as such here).

The 540-line (highlighted as a solid line) is located just behind the cold front with a classic cold-air advection behind the cold front and warm-air advection ahead of the cold front.

Don't become complacent; there may be other areas of icing around this low pressure system. However, the highest threat for significant icing is in the location

around the 540-line as indicated by the outlined area. The warm and cold fronts were added for clarity and don't appear on this chart.

The strong anti-cyclonic flow around the area of low pressure brings in cold air around and behind the cold front. Even though the wind is not depicted on this surface chart, the airflow will be nearly parallel to the isobars and perpendicular to the lines of constant thickness.

The thickness overlay provides a high glance value to quickly determine where adverse weather conditions may be located.

region. Similarly, cold-air advection (CAA) is the transport of cold air in the horizontal driven by the movement of cold air into a warmer region.

Advection can occur in the vertical, but let's stick to horizontal advection for now.

In the spring and fall and to some extent the summer, warm-air advection, along with moisture advection is a prime contributor for thunderstorms across much of the Midwest and

Southeast US. Along with surface heating, areas of warm-air advection at the surface destabilize the atmosphere ahead of the cold front increasing the likelihood of convective outbreaks.

In addition to the surface, warm-air advection can occur aloft. For example, this is common in the winter months as an area of low pressure and an associated warm front make their way northeastward along the spine of

the Appalachian Mountains. Warm air is carried over the mountains trapping cold, dense air beneath.

As a result, the cold air becomes dammed against the mountains with nowhere to go. Warm air over top cold, dense air, produces a sharp temperature inversion in the first two or three thousand feet creating a dangerous freezing-rain event for many of the Mid-Atlantic States.

Icing Potential

Another aspect of thickness utilized by meteorologists is to identify the separation between liquid and frozen precipitation. The 5400-meter thickness line (called the 540-line) is sometimes referred to as the rain-snow line. The 540-line *generally* demarcates frozen precipitation reaching the ground to the cold side of the line (towards the area of decreasing thickness) and liquid precipitation to the warm side of the line (towards the area of increasing thickness).

From a pilot's perspective, the strongest icing potential will occur *near* the 540-line in the area of the strongest cold-air advection and highest moisture content. The most significant icing occurs when the ambient air temperature is just below the freezing point (0 to -7 degrees C). Depending on altitude, the portion of the atmosphere that is on either side of the 540-line is highly representative of an atmosphere hovering around the freezing point. Icing does frequently occur in other areas around the low-pressure center, but may or may not be as significant.

Most of the typical mid-latitude cyclones (areas of low pressure) that march across the country in the winter normally do so while pushing the 540-line right along with it, ushering in colder air behind it.

Watching the location of the 540-line and the associated cold-air advection will point you to the areas containing the most significant icing. Keep in mind that the 540-line is not an absolute; instead, you should use it as a general guideline to supplement Airmet Zulu as well as other forecast

guidance and observations such as the all-important pilot reports (pireps).

Plotting Thickness

Thickness is not your run-of-the-mill forecast parameter so you won't see it on any of the familiar manual prognostic maps or while watching The Weather Channel. The thickness parameter can tell you a lot about what's happening at your location. For example, a trend for a decrease in thickness (or trend toward lower geopotential height) over some forecast period at your station typically means colder air moving in.

While atmospheric thickness can be calculated and displayed on a station-by-station basis, it's best viewed as an overlay on the mean sea level surface chart. It's extremely common to find the 1000-500 mb thickness displayed in decameters on the surface chart generated by most numerical weather prediction models (see forecasting models in the July issue).

If you compare these lines of thickness to the geopotential height lines on the 500 mb chart, they will look strikingly similar. That's because the height of the 500 mb surface is effectively the same as the difference between the 1000 mb and 500 mb surfaces. Consequently, you can think of the thickness lines on the surface chart as being an approximate overlay of the 500 mb heights.

Thickness Gradient

Meteorologists often speak about gradients. A gradient is a change of a specified parameter over some distance. The magnitude of the gradient often tells us something about the atmosphere. For example, a strong pressure gradient at the surface typically means higher winds at the surface.

Similarly, a large temperature gradient may be indicative of a frontal boundary. From the discussion above, we know that thickness and temperature are related. Consequently, the thickness gradient is a parameter that could be used to identify the boundary between cold and warm air. A cold

front will typically have a larger thickness gradient as compared to a warm front, and a larger gradient generally means a stronger front.

While the thickness parameter is not something we can use to predict the surface temperature or absolute temperature at any intermediate alti-

“ From a pilot’s perspective, the thickness parameter is more of a strategic planning tool. ”

tude, it can tell us where to shift our focus when looking at the synoptic picture. Even several days out, it will give us a broad-brush view of where the greatest risk of adverse weather may be located. Frequently, bad things happen in the areas of strongest thermal advection.

Knowing that doesn't automatically make you a weather nerd, but it does put one more weather tool in

your IFR kit. When you call to get your standard briefing, you'll not hear a flight service station specialist tossing around the 1000-500 mb thicknesses like they were METARs and TAFs for your proposed route of flight. Not only do they not have this information handy, but it's not what you need to know a few hours before your departure.

From a pilot's perspective, the thickness parameter is more of a strategic planning tool and is better utilized one-to-three days in advance of your planned departure time. Since atmospheric thickness directly relates to the average temperature, it won't tell you specific details such as the freezing level. A few hours before your flight, the freezing level is obviously more important than some average representation of temperature.

Scott Dennstaedt is a CFII and an IFR contributing editor who teaches aviation weather seminars. He's reachable at: scott@chesavtraining.com.

PV = nRT: It's The Law

Pick any two pressure surfaces. Now heat the air between these two surfaces. What happens? Given a constant pressure (P), constant amount of air (mass) and an increase in temperature (T), the Ideal Gas Law, $PV = nRT$ says that the volume (due to a decrease in density) must increase, thus push-

ing the two constant pressure surfaces farther apart.

In the atmosphere, this results in an increase in the height of your favorite pressure surface. Meteorologists commonly use the 1000 and 500 mb surfaces; however, any two pressure surfaces can be chosen.

